



User Guide

DP-33

(IDMT) Digital Over Current Relay

features

- True RMS Measurement with SPARC¹ and DCOP² Algorithm
- Auto / Manual Scroll for Real Time Display of Phase Current in (%)
- 6 Selectable IDMT Graphs + DTL
- Fault / Io-set & hi-set Trip LED Indication
- Fault Start Event Recording & LED Indication + Output³
- Pre-Alarm LED Indication + Output³
- Trip Event Memory (non-volatile 7 previous records for all phases)
- Fault Start Event Memory (non-volatile 4 previous records with phase info)
- Selectable Frequency (50 / 60 Hz)
- Programmable Relay Output Contact for K2
- Last Trip Elapsed Time (up to 99days)
- Software Lock to Prevent Unauthorized Setting
- Complies with IEC-60255-26/27 ; BS EN 50121-5 Standards
- ANSI Code: 50P, 51P
- External Plug-in Module for :- A-01s / A-01sp (RS-485 MODBUS RTU) isolated type

Panel Overview

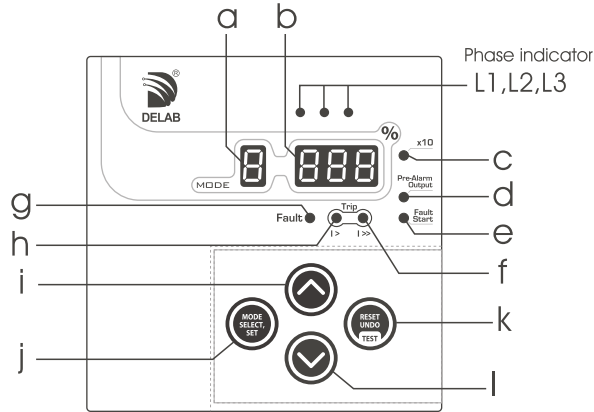

- a. single digit mode LED display
- b. 3 digit data LED display
- c. x 10
- d. Pre-Alarm output indication
- e. Fault start indication
- f. Hi-set trip indication
- g. Fault indication
- h. Lo-set trip indication
- i. up button / increment
- j. mode select / set button
- k. reset / undo / test trip button
- l. down button / decrement

Technical Data

Aux Power	: 65~275 Vac (45~65 Hz) ; 90~300 Vdc (for model 220a)
	18~72 Vdc (for model 024a)
Current Input (In)	: .5A or .1A (depending on model CT.../5A or CT.../1A)
Fundamental Frequency	: 50 or 60 Hz (software selectable)
Burden	: <0.3 VA @ In
Output Relay Rating	: SPDT 5A, 250V AC/DC
Consumption	: < 3 VA
Accuracy	: Current protection threshold (±5%), Time delayed (+5% or 50ms)
Display	: 7-Segment LED (3 + 1 digit)
Indication (LEDs)	: phase, x10, pre-alarm, fault start event, lo / hi-set trip, fault
Operating Temp.	: 0°C ~ +55°C
Humidity	: 56 days at 93%RH, 40°C non-condensing
IP Rating	: IP54 (front panel)
Weight	: 260 g

Parameter Setting Range

$I_D >$ (%) : lo-set trip	2% ~ 200% (step of 1%)
IDMT $I_D >$	6 IDMT + DTL
$TMS I_D >$: Time multiplier for IDMT	0.05 ~ 1.00 (step of 0.01)
$t_p >$ (sec) : lo-set trip time delay for DTL	0.03s ~ 20.0s
	0.03s ~ 0.10s (step of 0.01s)
	0.10s ~ 1.00s (step of 0.02s)
	1.0s ~ 20.0s (step of 0.1s)
$I_D >>$ (%) : hi-set trip	OFF or 20% ~ 2000%
	20% ~ 1000% (step of 10%)
	1000% ~ 2000% (step of 100%)
$t_p >>$ (sec) : hi-set trip time delay	Instant or 0.02s ~ 0.5s (step of 0.01s)

Casing

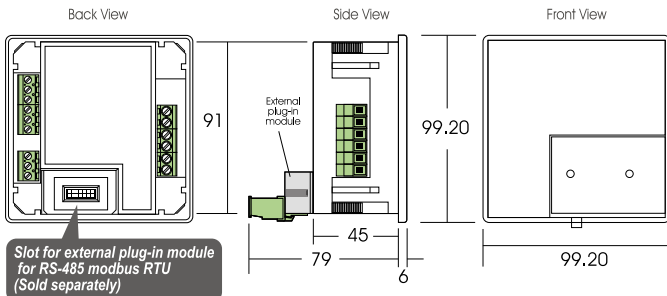

Panel Cut-out
92 x 92

Note: All measurement in mm.



Note: Specification subject to change without prior notification (please visit www.delab.com.my for latest specification)

YouTube : Delab Scientific Sdn. Bhd.



Wiring

When used without Earth Fault Relay

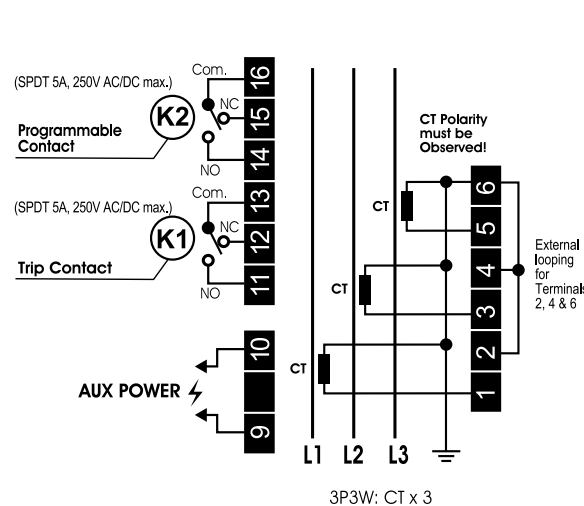

CT connection when used with Earth Fault Relay

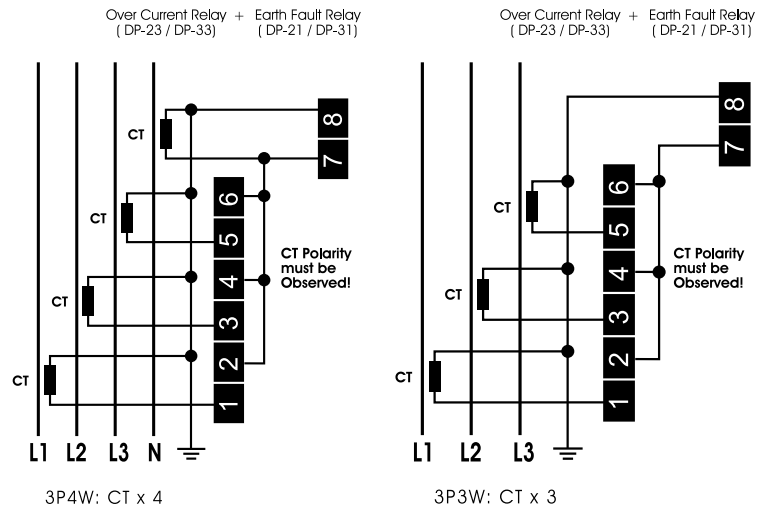

Modes

Factory Setting	80	I_p > (%)	lo-set trip
PARAMETER SETTING	n3.0	IDMT I_p >	6 IDMT + DTL
	0.10	TMs I_p > or t_p > (sec)	Time Multiplier or lo-set trip time delay
	600	I_p >> (%)	hi-set trip
	0.05	t_p >> (sec)	hi-set trip time delay
VIEWING INFO	b . 00 to 06	Trip memory	7 trip event memories (non-volatile)
	d	Last trip elapsed time	Last trip elapsed time
	00 to 04	Fault start memory	4 fault start event memories (non-volatile)
	F U E r	Version	Firmware version
SPECIAL SETTING MODE	F O P h	Operation hours	Device operated in hours (x 1000 hr.)
	OFF	S Software lock	: Keypad lock : OFF or ON
	Lc	n Trip relay K1 response type	: Latching (Lc) or Non-Latching (nLc)
	trP	n Output relay K2 function	: Programmable relay output
	nLc	n Trip relay K2 response type	: Latching (Lc) or Non-Latching (nLc)
	50	n Network frequency	: Selectable as : 50 Hz or 60 Hz
	On	S Standby mode	: Running LED bar : ON or OFF
	non	n Selection of plug-in module	: A-01s / A-01sp (RS485 modbus module) or none
	1	n Modbus address	: Selectable from 1 ~ 247
	96	n Baud rate setting	: Selectable from 3,6,12,24,48,96,192,288
non	n Parity setting	: Selectable : None / Odd / Even	
Factory Setting	End	End program setting	: Save changes and exit setting mode

Parameters Setting

Single digit mode display

Three digit mode display

MODE decimal Indicates seconds count

STEP 1

Press [SELECT] button while in default mode (when mode display is blank)
To scroll thru modes, just press & release the Select button

STEP 2

Press [UP] or [DOWN] button to desired value
For fast increment or decrement, press and hold the Up or Down button

STEP 3

Press [SET] button to store new value & proceed to next mode

RESET/UNDO

Press button to undo changes or exit mode

TEST TRIP

Press and hold 5 seconds to test trip device
5 flashes (mode decimal) = 5 seconds

All modes exit automatically if left untouched for more than 20 secs.

Info Viewing

b . **00** ~ **06**

Tripped values for last 7 events

Press [SELECT] button until mode **b** or hold [SELECT] button for 1 sec in any mode **0-9**. Display will show the tripped value for the most recent tripped event.

Single flash : Indicate a lo-set trip
Double flash : Indicate a hi-set trip

Manual tripped event will display a flashing **t r P**.
--- Indicate no tripping has occurred.

Press [SELECT] button again to scroll thru mode **00** to **06**. (Auto skip to mode **0** if memory is empty)

Skip directly to mode 0:
Hold [SELECT] button for 1 second.

Clear trip event memory:
Hold [RESET] button for 3 seconds in mode **b**. Press [UNDO] button to exit.

d

View last trip elapsed time

Press [SELECT] button until mode **d**. Display will show the elapsed time of last trip since last power up.
--- Indicate no tripping since last power up.

00 ~ **04**

Fault start event memory

Press [SELECT] button until mode **00**. If display shows **---**. (No fault event has occurred)
Press [SELECT] button again to scroll thru mode **00** to **04**. (Auto skip to next mode if no fault start event has occurred)

Clear fault start event memory:
Hold [RESET] button for 3 sec. in mode **00**. Press [UNDO] button to exit.

F U E r

Firmware version

Press [SELECT] button until mode **F U E r**. Display will show the firmware of the device. Press [UNDO] button to exit.

F O P h

Total operation hour

Press [SELECT] button until mode **F O P h**. Display will show a value (x1000 hr). Press [UNDO] button to exit.

0

Manual Scroll

Press [UP/DOWN] button when mode display is blank. Display will show the individual phase current (L1,L2,L3) in real time. Continue pressing the [UP/DOWN] button to scroll thru the next phase. Press [UNDO] button to exit.

99h 99m
Display up to 99 Hour 99 min

99d 99h
Display up to 99 Day 99 hour

00r 99d
Over 99 Days

Special Setting Modes

When no mode is selected (mode display is blank)

Press 'SELECT & RESET' button simultaneously & hold for 5 seconds until mode **0** appears

Press 'UP or Down' button to modify parameters

Press 'SET' button to confirm & proceed to next mode

L

Software keypad lock

OFF or **On**

r

Trip relay K2 response type

Lc : Latching trip **nLc** : Non-Latching trip

r

Trip relay K1 response type

Lc : Latching trip **nLc** : Non-Latching trip

F

Electrical network system frequency

Electrical network frequency setting:
50 : 50 Hz **60** : 60 Hz

r

Output relay K2 function

t r P : Tripping output (Lc / nLc)

Lo-LED : Lo-set fault start signal output (Lc / nLc)
Hi-LED : Hi-set fault start signal output (Lc / nLc)
Any-LED : Any fault start signal output (Lc / nLc)

Fault start event LED (e) indicates any detected fault events.
To clear event indication, press [RESET] button or scroll to mode **00** while no fault is present. K2 output will be activated when there is any fault start event if programmed is being set as 'AFS'.

To latch fault events output, select **n** to Lc in trip relay K2 response type.

-

Standby option

OFF : De-activate **On** : Activate

If set to on, after about 3 minutes of idle and no fault is detected, running LED bar will be displayed instead of the real time value. It automatically exits on fault detection or when any button is pressed. When device trips, standby mode is temporary de-activated until device is reset.

To toggle this setting, user can also press [SELECT] button when powering up the device.

n

Selection of plug-in module

n n : A-01s / A-01sp **non** : None

n

Modbus address

Selectable from 1~247

b

Baud rate setting

Set the baud rate in a modbus communication between host computer and device. Selectable as: (3 = 300, 6 = 600, 12 = 1200, 24 = 2400, 48 = 4800, 96 = 9600, 192 = 19200 or 288 = 28800) bps

n

Parity setting

non : None **Odd** : Odd **Even** : Even

Set the parity for Modbus communication between host computer and the unit.

End

End setting

Press [SELECT] button to exit & save the setting or [UNDO] button to go back.

Device Failure Output Function

off : Device failure output (nLc only)
K2 automatically turns ON when device is functioning normally.

Circuit Breaker Failure Output Function

off : Circuit breaker failure output (nLc only)
Activates K2 output if fault still exists after 100 ms of trip event.

Pre-Alarm Output Function

A90 : >90% of I_p > (Lc / nLc)
A95 : >95% of I_p > (Lc / nLc)

If K2 is programmed to pre-alarm A90 / A95, Pre-alarm output LED (d) will indicate the status of K2. Set **n** to Lc in trip relay K2 response type if need to latch pre-alarm events.

Press [RESET] button to clear output.

