

User Guide

TM-18c

Digital Earth Leakage Relay - DIN Rail Type

features

- True RMS Measurement with SPARC¹ and DCOI² Algorithm
- Fundamental Signal Detection³
- Real Time Display of I_{Δn} in Ampere
- Fault / I_o-set & hi-set Trip LED Indication
- Fault Start Event Recording + Output⁴
- Pre-Alarm Output⁴
- Trip Event Memory (non-volatile 7 previous records)
- Fault Start Event Memory (non-volatile 4 previous records)
- Selectable Frequency (50/60 Hz)
- Programmable Relay Output contact for K2
- Last Trip Elapsed Time (up to 99days)
- Auto Z.C.T. detection
- Software Lock to Prevent Unauthorized Setting
- 35mm wide DIN Rail mount
- Complies with IEC-60255-26/27 ; BS EN 50121-5 Standards

Panel Overview

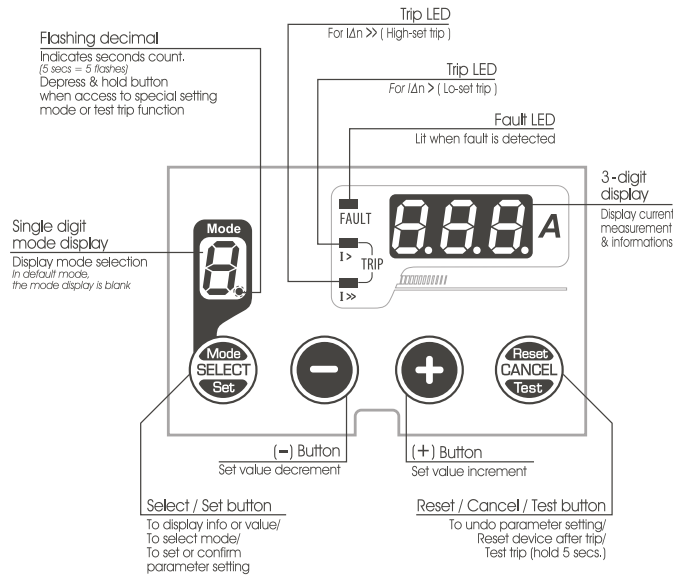

Technical Data

Aux Power	: 65 ~ 275 Vac (45 ~ 65 Hz); 90 ~ 300 Vdc (for model 220a)
	: 18~72 Vdc (for model 024d)
Fundamental Frequency	: 50 or 60 Hz (software selectable)
Current Input (I _{Δn})	: ZCT (multiple sizes from ID of 30~300mm)
Measurement Range	: 0.01 ~ 30.0 A
Output Relay Rating	: SPDT 5A, 250V AC/DC
Consumption	: < 3 VA
Accuracy	: Current protection threshold (±5%), Time delayed (+5% or 50ms)
Display	: 7-Segment LED (3 + 1 digit)
Indication (LEDs)	: Fault, I _o / hi-set trip
Operating Temp.	: 0°C ~ +55°C
Humidity	: 56 days at 93%RH, 40°C non-condensing
IP Rating	: IP55 (Mounted at relay front), IP52 (Mounted at relay rear)
Weight	: 200 g

Parameter Setting Range

I _{Δn} > (A) : lo-set trip	0.03 ~ 1.00 A (step of 0.01 A)
0.03 ~ 30.0 A	1.00 ~ 3.00 A (step of 0.05 A)
	3.00 ~ 10.0 A (step of 0.10 A)
	10.0 ~ 30.0 A (step of 0.50 A)
t > (sec) : lo-set trip time delay	0.03 ~ 0.10 s (step of 0.01s)
0.03 ~ 20.0 s	0.10 ~ 1.00 s (step of 0.02s)
	1.0 ~ 20.0 s (step of 0.1s)
I _{Δn} » (A) : hi-set trip	0.10~10.0 A (step of 0.10 A)
OFF or 0.10 ~ 30.0 A	10.0 ~ 30.0 A (step of 0.50 A)
t » (sec) : hi-set trip time delay	fixed @ 30ms

Casing (DIN Rail type)

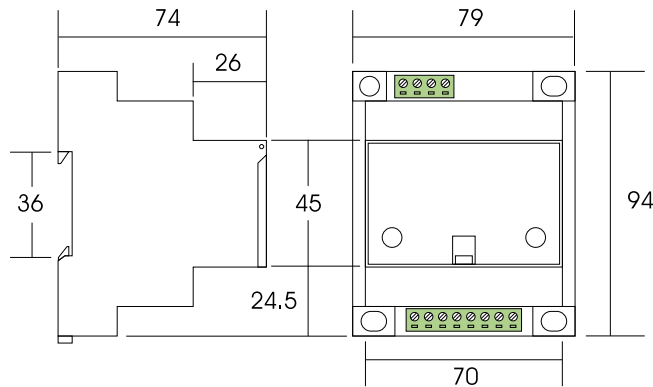

Note: All measurement in mm.



Note: Specification subject to change without prior notification
(please visit www.delab.com.my for latest specification)

YouTube : Delab Scientific Sdn. Bhd.



Wiring

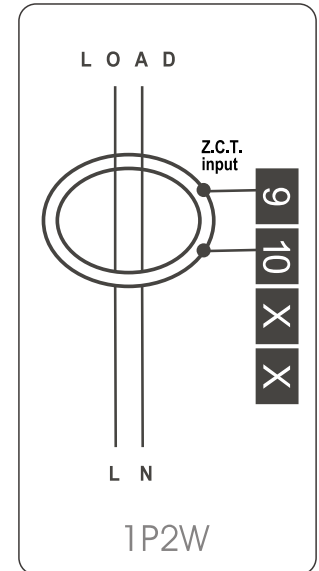
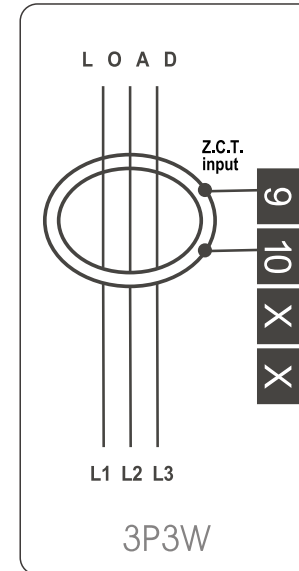
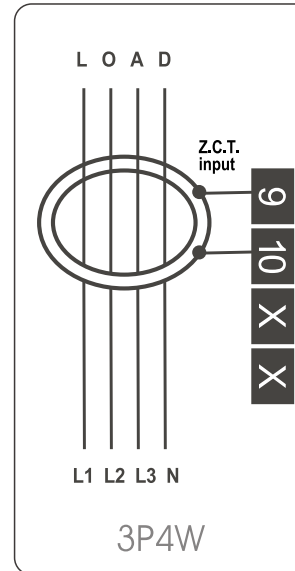
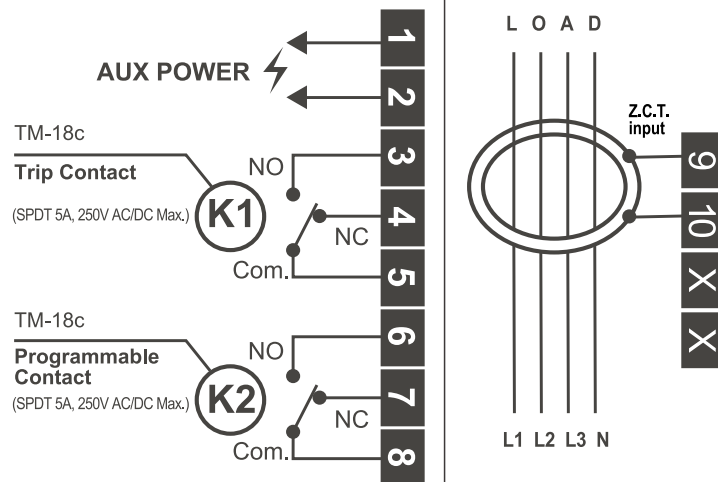



Modes



0.50	1 I _{Δn} > (A)	lo-set leakage current
0.30	2 t > (sec)	Trip time delay
OFF	3 I _{Δn} » (A)	hi-set leakage current

6 , 01 to 06	Trip memory	7 trip event memories (non-volatile)
d	Last trip elapsed time	Last trip elapsed time
01 to 04	Fault start memory	4 fault start event memories (non-volatile)
F U E r	Version	Firmware version
F o P h	Operation hours	Device operated in hours (x 1000 hr)

OFF	l Software lock	: Keypad lock : OFF or ON
Lc	01 Trip relay K1 response type	: Latching (Lc) or Non-Latching (nLc)
trP	02 Output relay K2 function	: Programmable relay output
nLc	02 Trip relay K2 response type	: Latching (Lc) or Non-Latching (nLc)
50	02 Network frequency	: Selectable as : 50 Hz or 60 Hz
On	- Standby mode	: Running LED bar : ON or OFF
Aut	00 Z.C.T. detection	: Auto detection or no detection
	End End program setting	: Save Changes and exit setting mode



Parameters Setting

1 I_{Δn} > (A) : To set lo-set leakage current

- Step 1 : Press [SELECT] button once to enter mode **1**.
Display will show the existing set value. (Range : 0.03 ~ 30.0 Ampere)
- Step 2 : Set the desired lo-set leakage current using the [+] or [-] button.
Newly selected value will flash.
- Step 3 : Press [SELECT] button to store / confirm new value and advance to mode **2** or press [CANCEL] button to undo changes.

2 t > (sec) : To set trip time delay

- Step 1 : Press [SELECT] button until mode **2** is displayed.
Display will show the existing set value. (Range : 0.03 ~ 20.0 seconds)
- Step 2 : Set the desired trip time using the [+] or [-] button.
Newly selected value will flash.
- Step 3 : Press [SELECT] button to store / confirm new value and advance to mode **3** or press [CANCEL] button to undo changes.

3 I_{Δn} » (A) : To set hi-set leakage current

- Step 1 : Press [SELECT] button until mode **3** is displayed.
Display will show the existing set value. (Range : OFF or 0.10 ~ 30.0 Ampere)
- Step 2 : Set the desired hi-set leakage current using the [+] or [-] button.
Newly selected value will flash.
- Step 3 : Press [SELECT] button to store / confirm new value and advance to mode **6** or press [CANCEL] button to undo changes.



Info Viewing

6, **01** ~ **06** Tripped values for last 7 events

Press [SELECT] button until mode **6**.
Display will flash the tripped value for the most recent tripped event.

Single flash : Indicate a lo-set trip	To reset trip event memory, hold [RESET] button for 3 sec. in mode 6 .
Double flash : Indicate a high-set trip	

Manual tripped event will display a flashing **trP**.
If display shows **---**. (No tripping has occurred)
Press [SELECT] button again to scroll thru mode **01** to **06**. (Auto skip to mode **6** if memory is empty)
To skip directly to mode **6**, hold [SELECT] button for 1 sec.
To exit, press [CANCEL] button.

d View last trip elapsed time

Press [SELECT] button until mode **d**.
Display will show **---** (device has no tripping since last power up).



To exit, press [CANCEL] button.

01 ~ **04** Fault start event memory

Press [SELECT] button until mode **01**. If display show **---** (no fault event has occurred).
Press [SELECT] button again to scroll thru mode **02** to **04**. (Auto skip to mode **6** if memory is empty)
To reset memory, hold [RESET] button for 3 seconds in mode **01**.
To exit, press [CANCEL] button.

F U E r Firmware version

This mode is not adjustable. For user to view firmware version.
Press [SELECT] button until mode **F U E r** is being displayed.
The display will show the firmware version of the device.
To exit, press [CANCEL] button.

F o P h Total operation hour

This mode shows the total time of the device that has been in operation.
Press [SELECT] button until mode **F o P h** is being displayed.
Display will show a value (x1000 hr).
To exit, press [CANCEL] button.



Special Setting Modes

When no mode is selected (mode display is blank)



Press 'SELECT & RESET' button simultaneously & hold for 5 seconds until mode **l** appears



Press ' - ' or ' + ' button to modify parameters



Press 'Set' button to confirm & proceed to next mode

l Software keypad lock

OFF or **On**

02 Electrical network system frequency

Electrical network frequency setting:
50 = 50 Hz **60** = 60 Hz

01 Trip relay K1 response type

Lc : Latching trip **nLc** : Non-Latching trip

- Standby option

OFF : De-activate **On** : Activate

02 Output relay K2 function

trP : Tripping output (Lc / nLc)

After about 3 minutes of idle and no leakage is detected, running LED bar will be displayed instead of the real time leakage current if activated. It automatically exits on leakage detection or Z.C.T. is not connected or when any button is pressed. When device trips, standby mode is temporary de-activated until device is reset.

Fault Start Output Function

LFS : Lo-set fault start signal output (Lc / nLc)
HFS : Hi-set fault start signal output (Lc / nLc)
AFS : Any fault start signal output (Lc / nLc)

When Z.C.T. is open-circuited, standby mode is temporarily de-activated until Z.C.T. is connected.
To toggle this setting, user can also press [SELECT] button when powering up the device.

To view recorded of fault start event, scroll to mode **01**

K2 output will be on if programmed as fault start event. To latch fault events output, select **02** to Lc in trip relay K2 response type.

00 Z.C.T. detection

OFF : No detection **Aut** : Auto detection

Device Failure Output Function

duF : Device failure output (nLc only)
K2 automatically turns ON when device and Z.C.T. are functioning normally.
K2 will turns OFF when device is malfunction or Z.C.T. is open-circuited.

2LE is being displayed and flashing instead of the real time leakage current when auto Z.C.T. detection is activated, it means that the Z.C.T. is not connected properly. User may need to check the wiring connection with the device.

End End setting

Press [SELECT] button to exit and save the setting or [CANCEL] button to go back.

Circuit Breaker Failure Output Function

cbF : Circuit breaker failure output (nLc only)
Activates K2 output if fault still exists after 100 ms of trip event.

Pre-Alarm Output Function

050 : >50% of I_{Δn} > (Lc / nLc)
090 : >90% of I_{Δn} > (Lc / nLc)
Set **02** to Lc in trip relay K2 response type if need to latch pre-alarm events.
Press [RESET] button to clear output.

02 Trip relay K2 response type

Lc : Latching trip **nLc** : Non-Latching trip